



STRUCTURAL PACKAGE DESIGN SERIES (4 VOLS.)

Basic Packaging	978-90-5768-143-1
Advanced Packaging	978-90-5768-144-8
Complex Packaging	978-90-5768-145-5
Fancy Packaging	978-90-5768-146-2

Specifications (for each volume)

424–432 pp | 17 x 22.5 cm (6¾ x 9 inch) | softcover + CD
€ 24.50 | £ 19.99 | \$ 34.99 | CAN\$ 44.99
EN | IT | FR | ES | DE | PT | JP | CH

Keywords

- 100% accurate packaging & folding templates
- photographs and 3-D structural drawings
- all designs and a software demo version on CD

Target Audience

- graphic, product & packaging designers
- packaging manufacturers

Description

Structural Package Design is a series of books, jam-packed with superb, 100% structurally accurate, scalable packaging templates. All designs are ready for immediate use and illustrated with 2-D and 3-D structural drawings and photographs. The CD contains the templates in various formats including EPS and PDF. Also included is a demos version of Illustrator®-Plug-Ins that provide professional package design possibilities.

Basic Packaging contains 300 designs, including designs of all major industry standards. **Advanced Packaging** contains 200 more complex designs. **Complex Packaging** contains 200 intricate designs that show some extraordinary possibilities, both technical and creative, in packaging. **Fancy Packaging** contains 200 exceptionally creative designs: a treasure trove of inspiration.

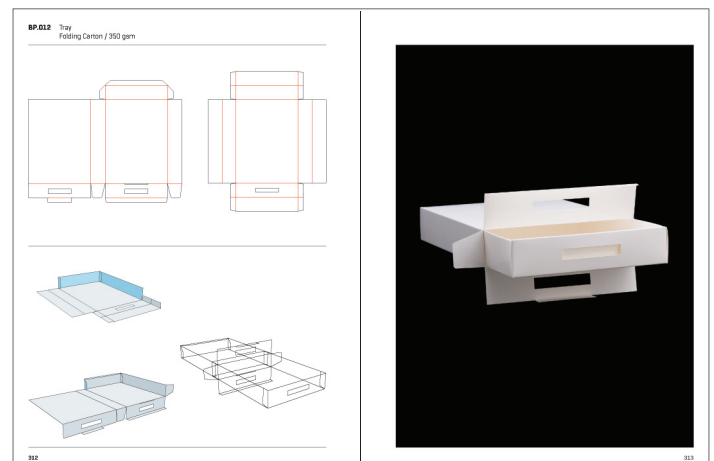

BASIC PACKAGING

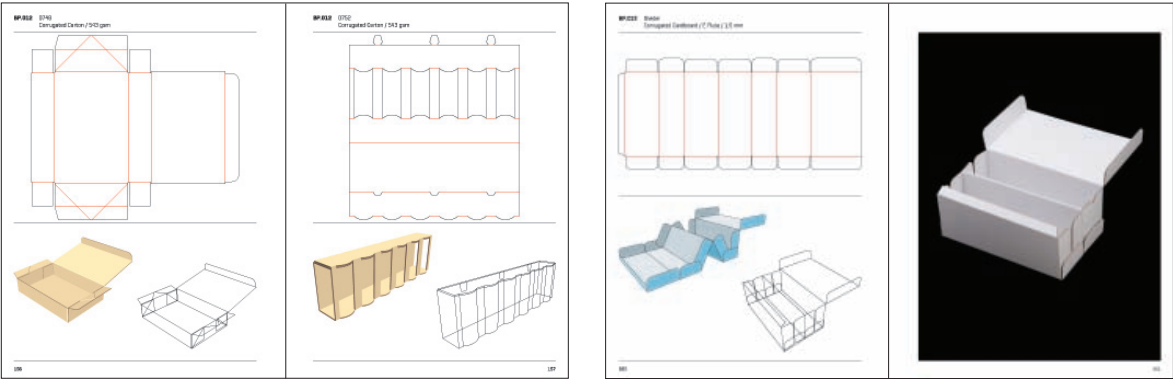

ADVANCED PACKAGING

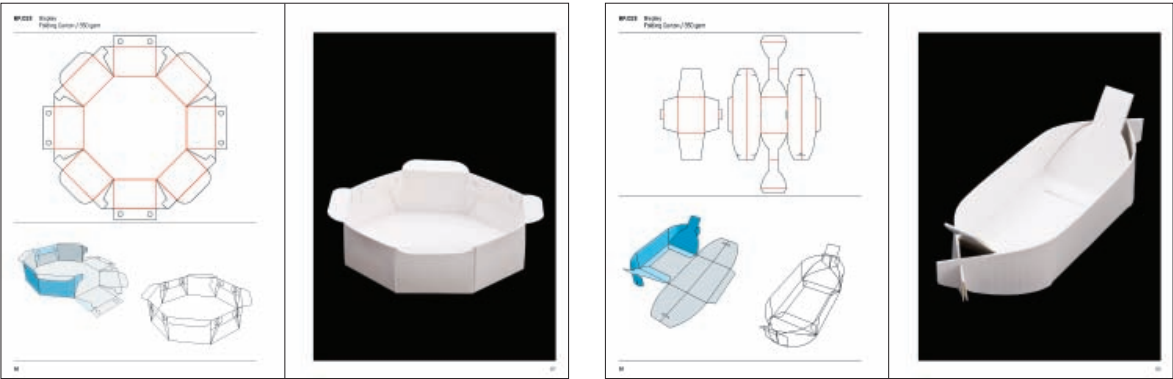

COMPLEX PACKAGING

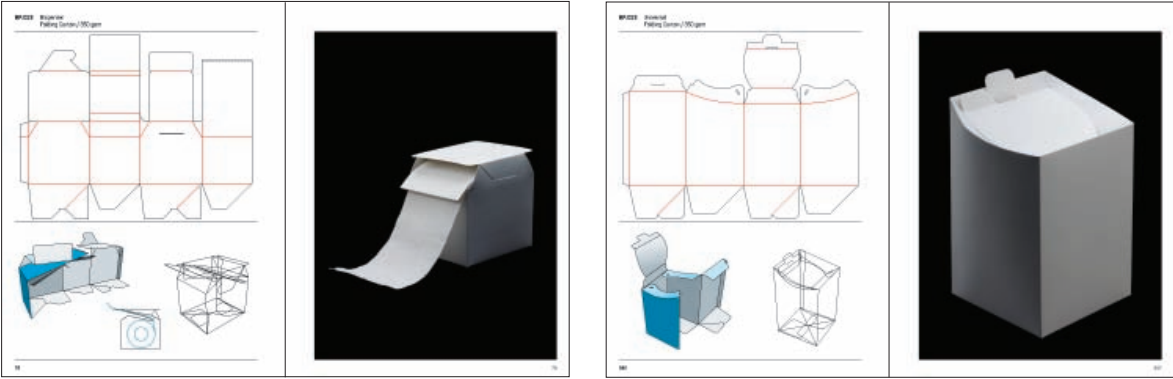

FANCY PACKAGING

